



The Professional Choice

OAW

Water Oil Cooler



OLAER OAW | Water Oil Cooler

General

Our OAW coolers are designed for a maximum working pressure of 300 psi. The most standard application for the OAW cooler involves a cold water circuit and a hot oil circuit. Fluids are not limited to oil and water however, see the Fluid Compatibility section in the OAW product literature for more information. Inlets and Outlets are clearly identified by the Olaer USA sticker affixed to the front of the unit. When in doubt, pour a liquid in one of the connections and note which connection it comes out of. This will be the inlet and outlet for one circuit (either oil or water). The other inlet should be located on the diagonal from the first inlet. Maximum cooling efficiency is achieved by cross flowing through the plates, the oil inlet and water inlet being located on a diagonal.

OAW to the max.

Extremely compact:

85-90% Reduction in volume and weight of a shell-and-tube heat exchanger of the same capacity.

**LOW WATER CONSUMPTION
ECONOMICAL OPERATION COMPACT**

Corrugated:

Plates made of 316 stainless steel brazed with pure copper.

**TURBULENT WATER FLOW
PREVENTS CLOGGING
REDUCES MAINTENANCE.
SMALLER SIZE MAKES IT EASY
TO INSTALL.**

**BROAD RANGE:
SEVERAL MODELS IN-STOCK
FOR IMMEDIATE DELIVERY.**

SAE O-Ring Connections:

Good for ease of assembly and leak proof operation.

Maximum Efficiency:

Maximum material efficiency. No "Dead Zone" outside gaskets because there is no need for gaskets. Up to 25% more capacity utilization.

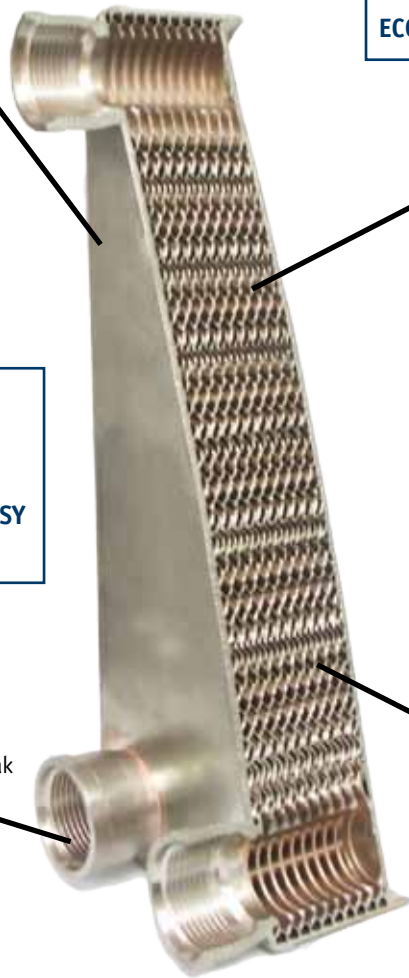

OAW 14 & OAW 34

Model	Cooling Capacity (*hp)	Connections	A (inches)	Weight (lb)	Volume (in ³)
OAW 14-10	2-7	3/4" SAE O-ring	1.4	1.4	15
OAW 34-20	6-33	1" SAE O-ring	2.3	9	74
OAW 34-40	20-69	1" SAE O-ring	4.1	15	149

* Cooling capacity is calculated with the following conditions. For other flow conditions, type of fluids or temperatures, please see page 7 or consult Olaer USA.

Oil type- ISO VG 32 - Oil/water flow ratio- 2:1 - Oil inlet temperature- 140 °F - Water inlet temperature- 80 °F

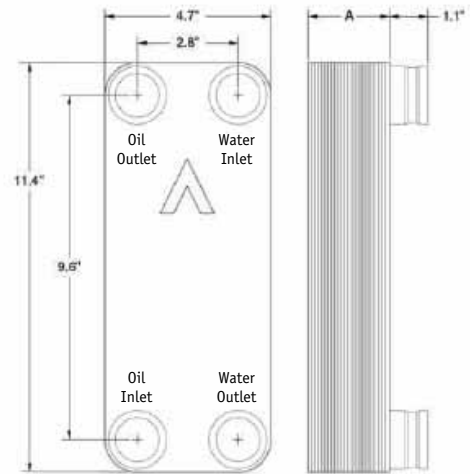
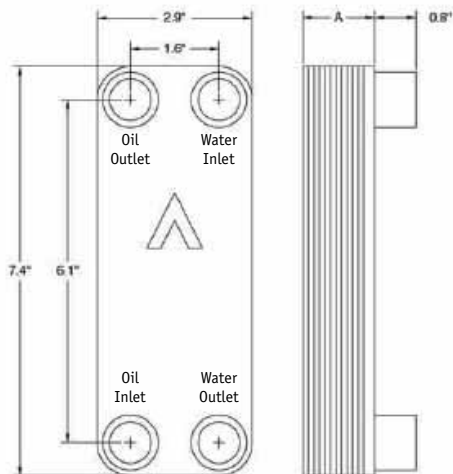
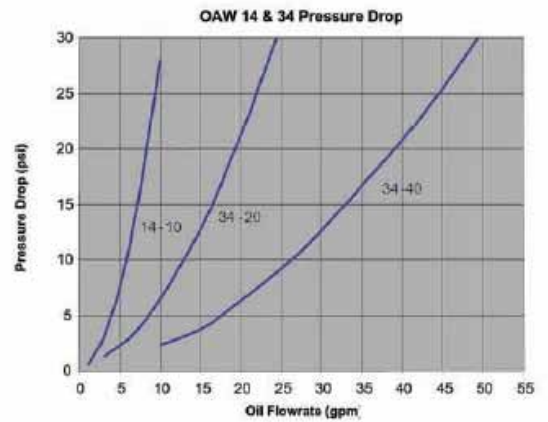
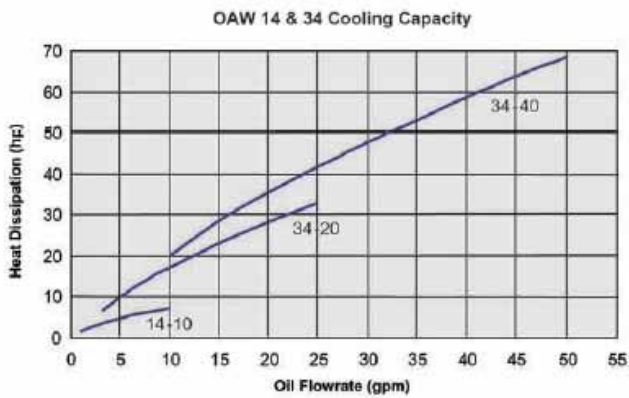

OAW 46 & OAW 61

Model	Cooling Capacity (*hp)	Connections	A (inches)	Weight (lb)	Volume (in ³)
OAW 46-40	21-94	1 1/4" SAE O-ring	3.9	13	200
OAW 46-60	23-142	1 1/4" SAE O-ring	5.7	18	300
OAW 61-40	27-98	1 1/4" SAE O-ring	3.9	19	271
OAW 61-60	53-152	1 1/4" SAE O-ring	5.7	27	406
OAW 61-80	79-198	1 1/4" SAE O-ring	7.4	34	542

* Cooling capacity is calculated with the following conditions. For other flow conditions, type of fluids or temperatures, please see page 7 or consult Olaer USA.

Oil type- ISO VG 32 - Oil/water flow ratio- 2:1 - Oil inlet temperature- 140 °F - Water inlet temperature- 80 °F

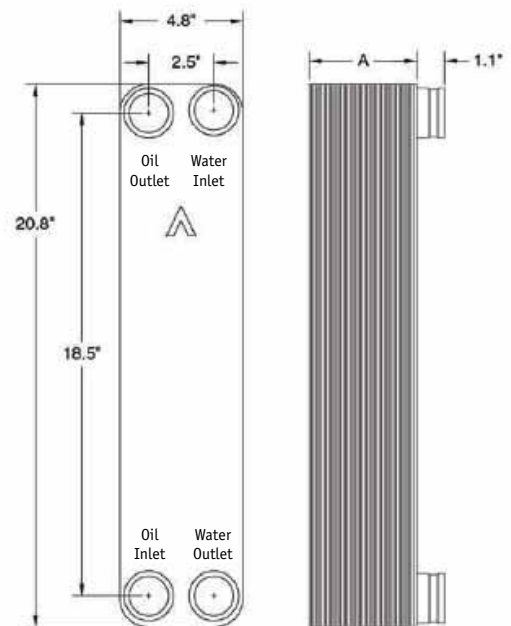
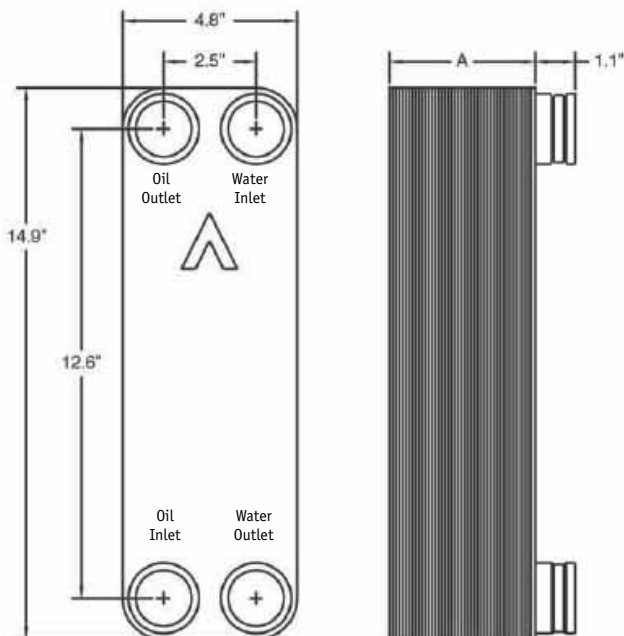
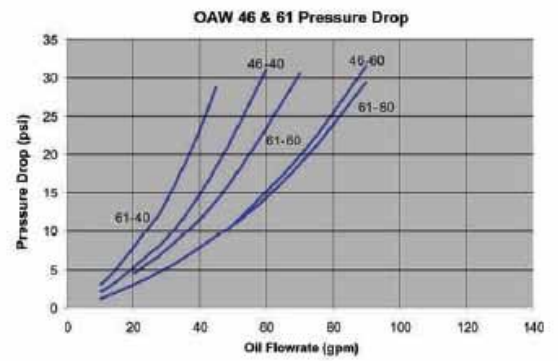
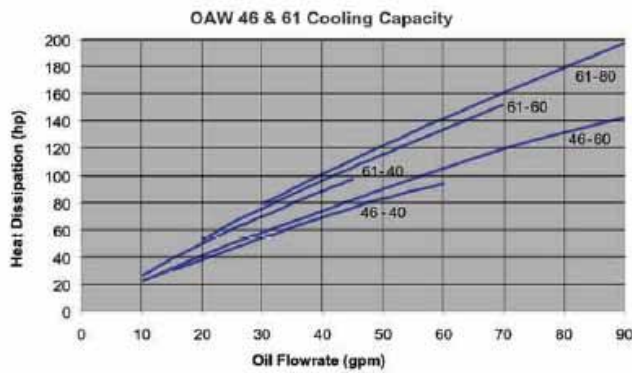

OAW 95 & OAW 126

Model	Cooling Capacity (*hp)	Connections	A (inches)	Weight (lb)	Volume (in ³)
OAW 95-40	50-150	1½" SAE O-ring	4.1	44	427
OAW 95-60	63-171	1½" SAE O-ring	6.0	59	641
OAW 126-60	84-259	1½" SAE O-ring	6.1	79	856
OAW 126-80	138-274	1½" SAE O-ring	7.9	97	1142

* Cooling capacity is calculated with the following conditions. For other flow conditions, type of fluids or temperatures, please see page 7 or consult Olaer USA.

Oil type- ISO VG 32 - Oil/water flow ratio- 2:1 - Oil inlet temperature- 140 °F - Water inlet temperature- 80 °F

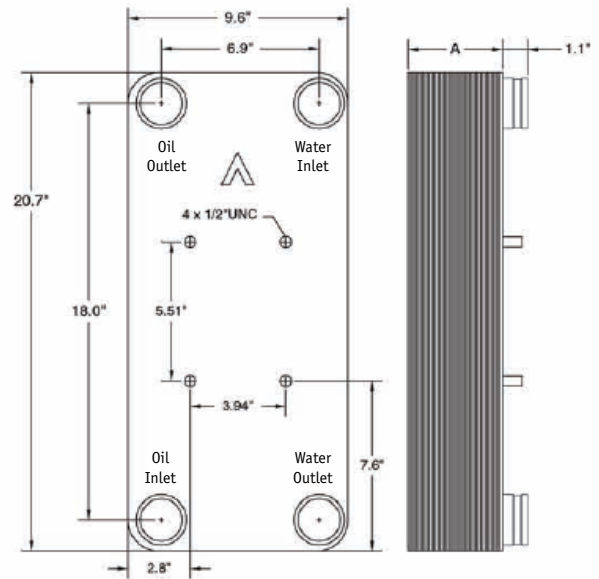
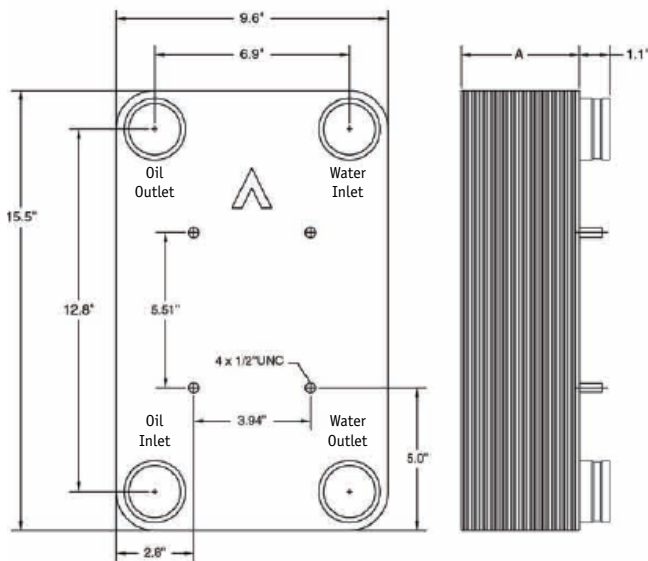
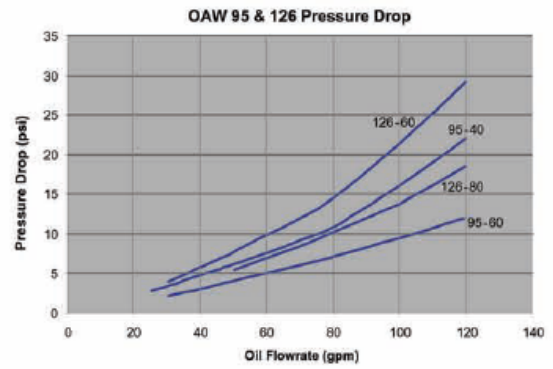
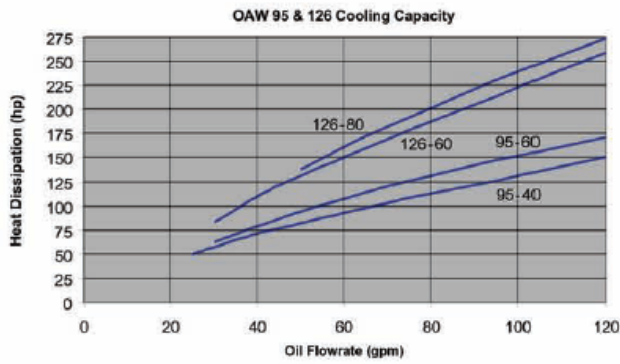

Installation

Installation Instructions for OAW Coolers

The OAW coolers are designed for a maximum working pressure of 300 psi. The most standard application for the OAW cooler involves a cold water circuit and a hot oil circuit. Fluids are not limited to oil and water however, see the Fluid Compatibility section for more information.

Inlets and Outlets are clearly identified by the Olaer USA sticker affixed to the front of the unit. When in doubt, pour a liquid in one of the connections and note which connection it comes out of. This will be the inlet and outlet for one circuit (either oil or water). The other inlet should be located on the diagonal from the first inlet.

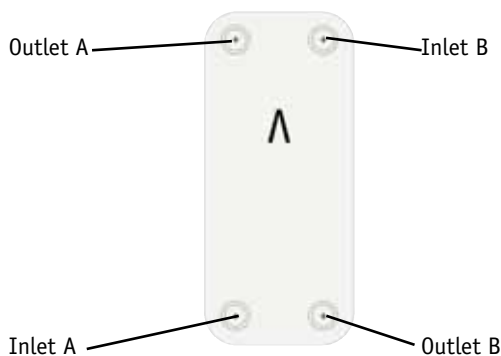

Maximum cooling efficiency is achieved by cross flowing through the plates, the oil inlet and water inlet being located on a diagonal. Failure to have the cooler attached in this manner will lead to a decrease in efficiency.

The cooler may be mounted in any position. However, requirements for draining the circuits should be taken into consideration.

The OAW coolers must not be installed into a rigid frame. Use the Olaer USA purpose made brackets (or "Armaflex" equivalent) to provide a "soft, elastic installation". The OAW 95 and 126 series coolers come equipped with stud bolts to assist in mounting. However, these bolts alone should not be used to suspend the cooler. All tubing should be done in such a way as to minimize vibrations to the cooler. When installed on a return line, the cooler should be connected using flexible hoses.

When to clean

Fouling occurs mainly on the water side of the cooler. Fouling can be detected by monitoring the inlet and outlet temperatures and/or the pressure drop across the cooler. Fouling will result in decreased heat transfer, producing temperature differences lower than specified. Fouling also restricts the passages and thus causes an increase in velocity. This will produce an increase in the pressure drop across the cooler. When either the temperature difference or the pressure drop is significantly different from specified values, cleaning should be performed.

Methods of Cleaning

If cleaning the cooler is required, backflushing with water will remove most of the soft deposits. If fouling appears in the form of hard deposits, circulate a weak acid through the cooler in reverse direction to normal water flow. Use 5% phosphoric acid for infrequent cleanings. For more frequent cleaning, use 5% oxalic acid or similar weak organic acid. Afterwards flush with a large quantity of water to remove all acid from the cooler before starting up the system again. Never wait until the cooler is completely clogged before cleaning!

Filters or Strainers

When there are particles in the fluid that could clog the cooler, filters or strainers should be used. Particles up to 1mm diameter will not cause any problems.

Fluid Compatibility

On the oil side, most synthetic and petroleum based fluids may be used. For aggressive oils, please contact Olaer USA for compatibility. On the water side, de-mineralized and untreated water may be used without concern. When water is chemically treated please contact Olaer USA for suitability. Sea water cannot be used in OAW coolers. For sea water applications, please contact Olaer USA on information on titanium coolers. Do not use ammonia in the OAW coolers.

Correction factors for other oil types, temperatures and flow rates.

All of the cooling curves are based on very specific conditions. These include using an ISO VG 32 oil, having an oil/water ratio of 2:1, and having an oil/water inlet difference of 60 °F. For other conditions the following correction factors should be used.

Correction Factors for Other Oil Types.

Cooling Capacity:

Multiply the requested cooling capacity with the correction factor Kv.

Oil Pressure Drop:

Multiply the pressure drop with the Correction factor Kp.

Table 1

Viscosity Class	Cooling Capacity factor, Kv	Pressure Drop factor, Kp
ISO VG 22	0.95	0.9
ISO VG 32	1.0	1.0
ISO VG 46	1.05	1.3
ISO VG 68	1.2	1.7
ISO VG 100	1.35	2.2
ISO VG 150	1.6	3.0
ISO VG 220	1.9	4.3

Correction Factors for Other Inlet Temperature Differences

Cooling Capacity:

For inlet temperature differences other than 60 F, multiply the requested cooling capacity by the correction factor Kt.

Table 2

ETD	30	40	50	60	70
Kt	1.87	1.43	1.17	1.0	0.88

Correction curves for other oil/water flow ratios

Cooling Capacity

For all other oil/water flow ratios other than 2:1, divide the requested cooling capacity by the factor Kr obtained from the curves in Graph 3.

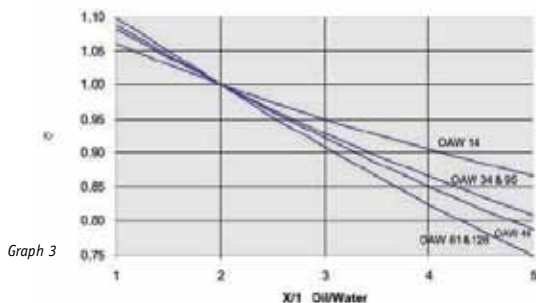

Graph 3

Sizing Example

Conditions:

Oil type:	ISO VG 68
Oil Flow:	40 gpm
Desired cooling capacity	Qr 40 hp
Oil temperature in	To 140 °F
Water temperature in	Tw 100 °F
Available water flow	10 gpm
Maximum Pressure Drop	30 psi

ETD = To - Tw = 140 °F - 100 °F = 40 °F

The design cooling capacity (Qd) is the cooling capacity used when selecting a suitable cooler. Qd is calculated by multiplying Qr by the factors Kv and Kt (found in tables 1 and 2 respectively) and then dividing by the Kr factor found from Graph 3.

$$Qd = \frac{Qr \times Kv \times Kt}{Kr} = \frac{40 \text{ hp} \times 1.2 \times 1.43}{0.82} = 83 \text{ hp}$$

According to the cooling capacity curves on page 4, the minimum size cooler for these conditions is an: OAW 61-40.

The oil pressure drop, can be found from the pressure drop curve and it should be multiplied by the Pressure Drop Factor, Kp from Table 1.

DPOil = p x Kp = 23 psi x 1.7 = 39.1 psi.

In this case the pressure drop exceeds the maximum allowable. The next size cooler would be an: OAW 61-60

The pressure drop for this cooler would be:

DPOil = p x Kp = 12 psi x 1.7 = 20.4 psi.

Therefore the correct size cooler would be the OAW 61-60.

For assistance with calculations, please contact Olaer USA.



- in Fluid Energy Management

Global perspective

and local entrepreneurial flair



Olaer is a global player specializing in innovative, efficient system solutions for temperature optimization and energy storage. Olaer develops, manufactures and markets products and systems for a number of different sectors, e.g., the aircraft, engineering, steel and mining industries, as well as for sectors such as oil and gas, contracting and transport, farming and forestry, renewable energy, etc.

All over the world, our products operate in the most diverse environments and applications. One constantly

repeated demand in the market is for optimal energy storage and temperature optimization. We work at a local level with the whole world as our workplace – local entrepreneurial flair and a global perspective go hand in hand.

Our local presence, long experience and a wealth of knowledge combined with our cutting-edge expertise give you the best possible conditions for making the professional choice.